

Warmboard-R (Remodel Panel) Installation Guide



For questions call 1-877-338-5493 or visit warmboard.com

Revised Sept. 1, 2011



Table of Contents

Important Installation Highlights.....	Page 2
Panel Types.....	Page 3
Example of Panel and Tubing Design.....	Page 4
Tools Needed.....	Page 5
Installing Warmboard-R to Existing Subfloor.....	Page 6
Custom Routing.....	Page 7
Choosing the Correct Router for Custom Routing.....	Page 8
Approved Tubing List.....	Page 9
Tubing Installation Process.....	Page 10-11
Manifold Installation.....	Page 12
Installing Solid Wood Flooring.....	Page 13-16
Installing Engineered, Laminate and Bamboo Flooring.....	Page 17-18
Hardwood Manufacturers.....	Page 19
Installing Tile.....	Page 20-21
Installing Backerboard to Warmboard-R.....	Page 22
Installing Carpet	Page 23-24
Installing Cork.....	Page 25
Installing Vinyl.....	Page 26
Installing Linoleum.....	Page 27
Installing Over an Existing Concrete Slab.....	Page 28-29
Tubing Repair.....	Page 30
Performance / Water Temperature Chart.....	Page 31
Finish Floors R-Values Chart.....	Page 32



10 Important Installation Highlights

1. We recommend the existing subfloor to be reasonably smooth and flat prior to the installation of Warmboard-R. Inspect for squeaks and refasten to joists if necessary.
2. The existing subfloor needs to be dry prior to the Warmboard-R installation. The Warmboard-R panels cannot be exposed to rain before or after installation.
3. Use the Warmboard-R (provided by Warmboard, Inc.) alignment pins when fastening the R-panel.
4. Use Warmboard approved tubing only. Use electrical nail plates to hold down tubing and remove them before the installation of finish floors (see our approved tubing list on page 9). Silicone or other types of adhesives should not be used.
5. Tubing layout field revisions are approved and welcomed, do not exceed 300 linear foot per loop.
6. Custom routes require the use of a 1-1/2 horsepower router minimum. A Porter Cable router will interface with the Warmboard, Inc. provided metal template guides.

Do not attempt a custom route without the proper metal template guide attached to the router (see page 7-8).
7. The Warmboard heating system should not be commissioned to have the finish floor temperatures exceed 85° (industry standard).
8. Review this installation manual before installing finish floors.
9. Best practice for optimum performance is to insulate with an R-19 or R-30 between existing floor joists, below the Warmboard-R panel.
10. Call Warmboard at 877-338-5493 if you have any questions.



Panel Types

The Warmboard-R installation consists of two panel types.

Each panel measures 23-7/8" W x 47-7/8" L x 13/16" H.

Panels are made from OSB and are square edged.

RT TURN PANEL



RS STRAIGHT PANEL



Note: Filler panels are also available.



Example of Panel and Tubing Design

Warmboard-R Panel Layout Example

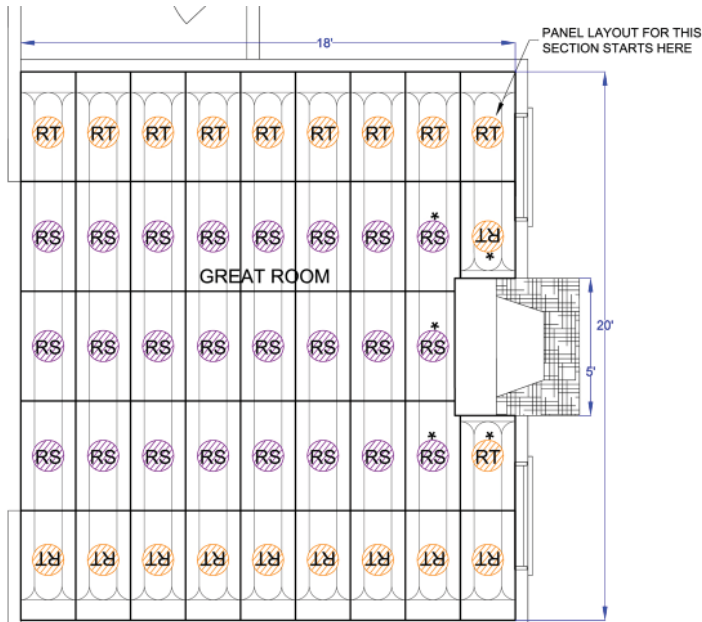

Warmboard, Inc. does encourage confident contractors and homeowners to draw their own panel and tubing shop drawings.

We recommend loop lengths of 300 foot maximum, from supply to return manifold.

The modular design of the Warmboard-R panel allows opportunity for little or no custom routing.

If the finish floor is a nail down hardwood, Warmboard-R panel should install perpendicular to the hardwood planks.

If this is not an endeavor you want to take on, Warmboard, Inc. can provide the shop drawings.

Warmboard-R Tubing Layout Example

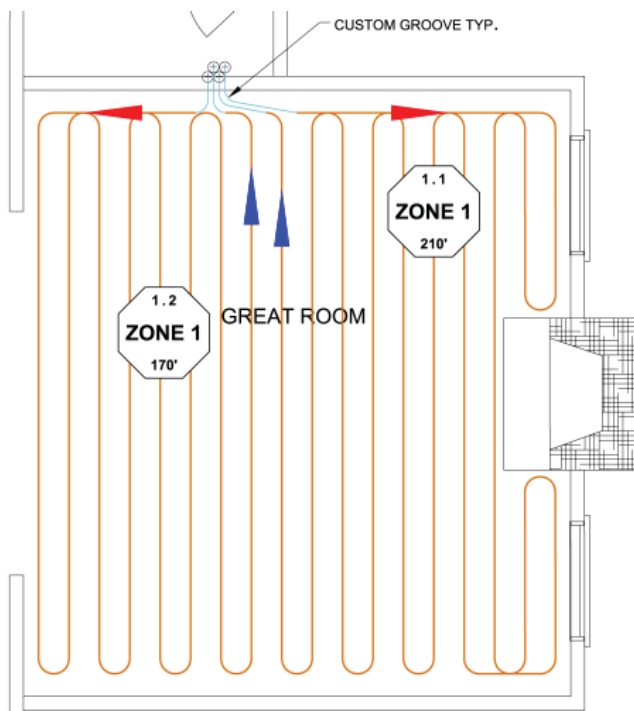



Tools Needed



Warmboard-R Installation Kit contains:

- 3 - Custom routing templates/guides (wood)
- 1 - 5/8" router bit
- 2 - Alignment pins (metal)
- 1 - Porter Cable template guide
- 1 - Porter Cable guide lock nut

Other materials and tools needed on site:

- Electrician nailing plates
- Heavy roller (typically a linoleum roller)
- Warmboard approved tubing
- Shop vacuum
- Drill motor with a 3/4" drill bit
- Pex tubing cutter
- Felt tip marking pen
- Warmboard-R Panel and Tubing Plans
- Tubing un-coiler (optional)

Materials and tools needed for custom routing:

- Porter Cable router or similar that will interface with Warmboard supplied template guide and guide lock nut, 1-1/2 horsepower minimum required (see page 8)
- 4" grinder or dremel



Installing Warmboard-R to Existing Subfloor

The existing subfloor is required to be flat and smooth before the installation of Warmboard-R. Inspect the subfloor for evenness along the joists and flatness between the joists.

If necessary, sand the subfloor, install extra blocking below the subfloor, and refasten the subfloor to even areas. Also, inspect for squeaks and refasten with decking screws as necessary.



Photo 1.1

The subfloor and Warmboard-R need to be dry. The Warmboard-R cannot be exposed to any rain before or after installation.

Cutting and installing the Warmboard-R is very simple and intuitive. The panels can be trimmed with a standard skill saw or table saw and will rip just like ordinary OSB. It is best to cut the panels with the aluminum side down. We recommend two different options for attaching the panels to the subfloor.

It is crucial to use the panel alignment pins (Warmboard, Inc. supplied) to line up channels from panel to panel (see photo 1.1).

1. Screw fasteners method:

Use a “GRK multi purpose screw 9 x 1-3/4” Uber Grade” with a top 3/4” smooth shank. The use of an equal product is acceptable (see photo 1.2). Fasten with screw pattern of 3 rows of 4 (see photo 1.1).

- No pre-drilling required
- Self counter sinking
- No adhesive needed

2. Nail and glue method:

Use a construction adhesive designed for bonding OSB and plywood, “Loctite PL Wood” is an excellent choice. The use of an equal product is acceptable. Follow all directions as specified by the adhesive manufacture.

For nailing use a ring shank or a screw nail. To determine the appropriate length of nail to use, evaluate existing thickness of subfloor and add 13/16”, this will be the minimum length. Fasten nails with a pattern of 3 rows of 4.

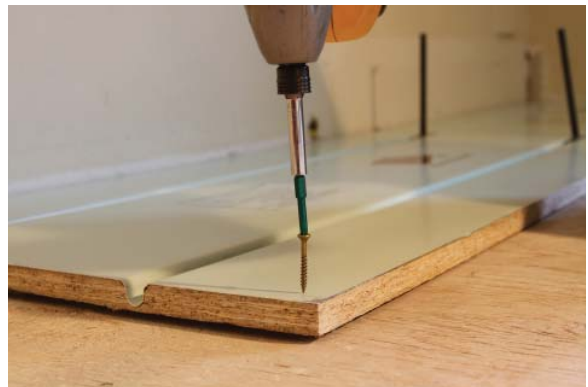

Photo 1.2



Custom Routing



5/8" Router
Bit

Template
Guide

GuideLock
Nut

- Review all tubing layout plans. Using felt tip marker and wood templates (included in installation kit) mark all areas on Warmboard-R that will require custom routing.
- Prepare router with router bit, template guide and template guide lock nut.

Note - Router is not provided (see page 8)



Procedure:

- Place the appropriate Warmboard, Inc. custom routing template over the area to be routed.
- Fasten with 3 screws to securely hold the wooden template in position.
- Proceed with router (ensure that router bit and metal template guide are properly installed).
- When route is complete, remove wooden template guide, vacuum channel with shop vac, and use 4" grinder to remove aluminum burrs.





Choosing the Correct Router for Custom Routing

IMPORTANT: Not all Porter Cable sub-bases will interface with Warmboard, Inc. supplied Porter Cable metal template guides.



- The Porter Cable router shown on left has the correct sub-base to interface with the Warmboard, Inc. supplied metal template guide.



- Photo on right is an example of a Porter Cable router with the correct sub-base and the Warmboard, Inc. supplied metal template guide installed.



- **CAUTION:** Photo on the left is an example of a Porter Cable router that has a sub-base that **WILL NOT INTERFACE** with the Warmboard, Inc. supplied metal template guide.
- This interface problem can be corrected with the purchase of a Porter Cable sub-base shown at left. This accessory only fits on some Porter Cable routers.

- Notes:**
- A 1-1/2 minimum horsepower router is required.
 - Size of supplied metal template guide is 1" OD.
 - Other routers with 1" OD metal template guides can be used.



Approved Tubing List

The tubing types/brands listed below are approved for use with Warmboard-R panels:

Pex Aluminum Pex Tubing 1/2" I.D.:

- AIM- Pex Aluminum Pex
- Allied Pipe Systems- Pex Aluminum Pex
- Aqua Therm- Pex Aluminum Pex
- ComfortPro- Pex Aluminum Pex
- EHT (Efficient Heating Technology)- Pex Aluminum Pex
- Excel- Pex Aluminum Pex
- Henco- Pex Aluminum Pex
- Hydro-flex- Pex Aluminum Pex
- HYDRONX- Pex Aluminum Pex
- Inferno- Pex Aluminum Pex
- Infloor Heating Systems- Pex Aluminum Pex
- Mr. Pex- Pex Aluminum Pex
- RHT- Pex Aluminum Pex
- Rifeng- Pex Aluminum Pex
- Roth- Pex Aluminum Pex
- Uponor- Multi-Layer composite tubing (MLC) Pex Aluminum Pex
- Watts- Pex Aluminum Pex
- Weil-McLain- Pex Aluminum Pex
- Zurn Alumicor- Pex Aluminum Pex

Standard Barrier Pex 1/2" Tubing I.D.:

- Mr. Pex (LK Pex AB)
- Rehau Raupex Oxygen barrier
(manufactured after 3/8/11-date printed on tubing)
- Uponor HePex
*(*manufactured after 3/12/10-see note below)*
- ViegaPEX Barrier
- Watts RadiantPEX+

CAUTION!

Viega Fostapex is not approved, the diameter is too large to fit into the Warmboard groove.

Notes about Pex Tubing:

Other brands of Pex Tubing may be acceptable. Please check with Warmboard's Technical Department.

Silicone or other types of adhesives are not to be used when installing any Standard Barrier Tubing or Pex Aluminum Pex Tubing.

The use of nail plates is necessary to hold down tubing in channels. Remove all plates before the installation of finish floors.

**To confirm that the hePEX tubing is manufactured after 3/12/10, find the "NOT FOR POTABLE WATER" labeled on the tubing. Check the number that begins with two letters (example UB13100330). The last six digits of this number should be 100312 or greater.*



Tubing Installation Process

Clean channels and entire panel

- Use a shop vacuum and leaf blower if available.
- Be sure channels are completely free of any debris (see photo 1.3).
- This simple, but important step of the process will ensure the tubing sits flush and level.

Layout tubing loops on panel surface

- Use a permanent marker and clearly mark and layout the tubing path for each loop to avoid any future confusion.
- Mark manifold locations, supply and return lines.
- Mark the areas that require a custom route. **Note** - the router base does require room to operate, the router base will not work directly next to an existing wall.

Return lines back to manifolds (4 different methods)

- Method 1- uses the pre-grooved channels in the panels to return the tubing to the manifold location.
- Method 2- uses the custom routes on the surface of the panel to return the tubing back to the manifold location.
- Method 3- uses the bury point, the tubing drops below the subfloor (see figure 1.1) to return the tubing back to the manifold location.
- Method 4- uses the “panel cut back” (see figure 1.2) to create a tubing channel above the subfloor for the tubing to return back to the manifold.



Photo 1.3

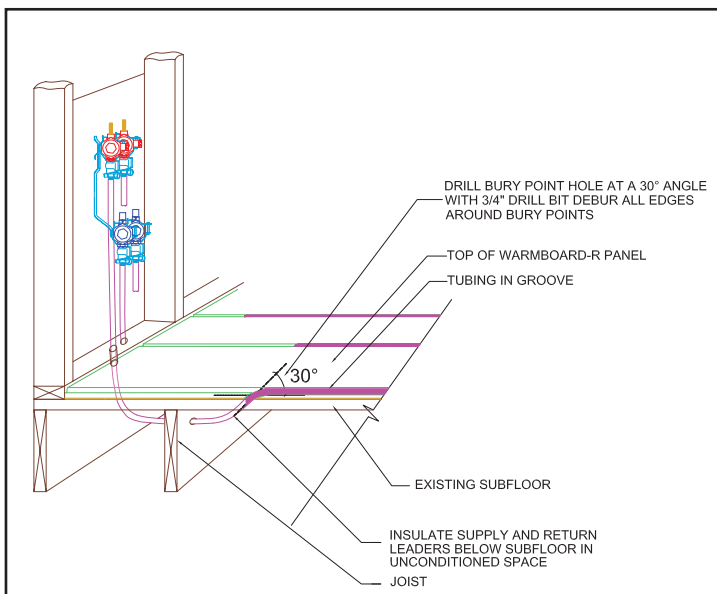

Figure 1.1 - Bury Point Example

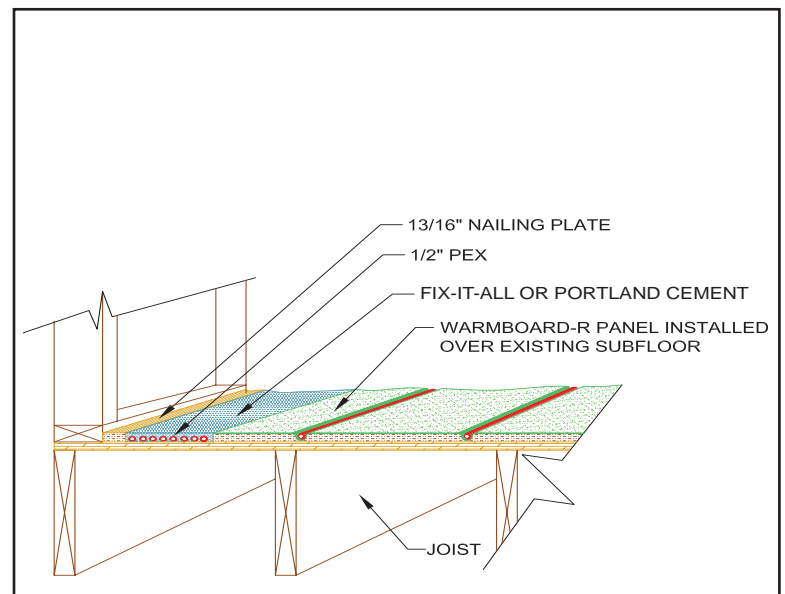

Figure 1.2 - Panel Cut Back Example



Tubing Installation (con't)

Perform custom routes

- Do not attempt a custom route without the proper metal template guide attached to the router (see page 7-8).
- Review page 8 of this install guide to evaluate and understand router specification details.
- Use the wood templates (supplied by Warmboard, Inc.) to complete process (see page 7).

Install tubing

- Use a tubing brand from the Warmboard “Approved Tubing List” only.
- Use a heavy roller, or a wooden block and hammer to secure tubing firmly into the channel (see photo 1.4 and 1.5).
- Use nail plates as necessary to hold down tubing at the 180 degree turns, remove plates the day before finish floors are installed (see photo 1.6 and 1.7).
- Do not use silicone or adhesive in channels, this will cause the tubing to sit too high in the channel.
- Tape ends of tubing to prevent any debris from clogging the lines.
- For large jobs a tubing uncoiler can be an excellent investment.

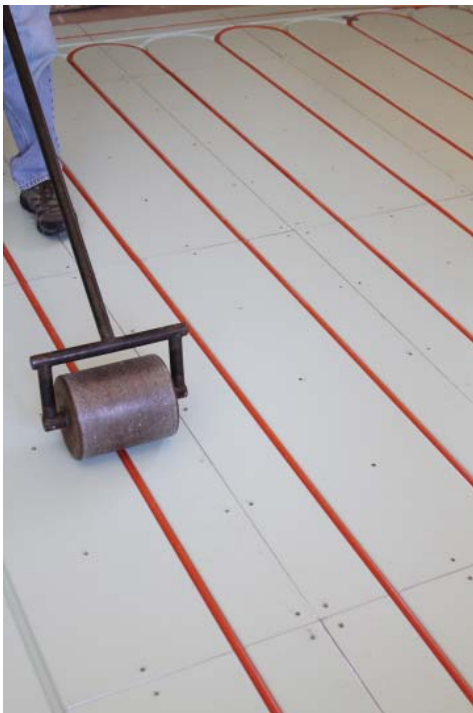

Photo 1.4



Photo 1.5



Photo 1.6



Photo 1.7



Manifold Installation

Install Manifold

- Follow all installation details and specifications documented by manifold manufacturer.
- Manifolds are usually placed in closets between interior wall stud bays with access door.
- Pressure test all loops with air, a minimum of 60 psi.
- Clearly mark all supply and return loops, documenting rooms and zones on manifolds to avoid future confusion.

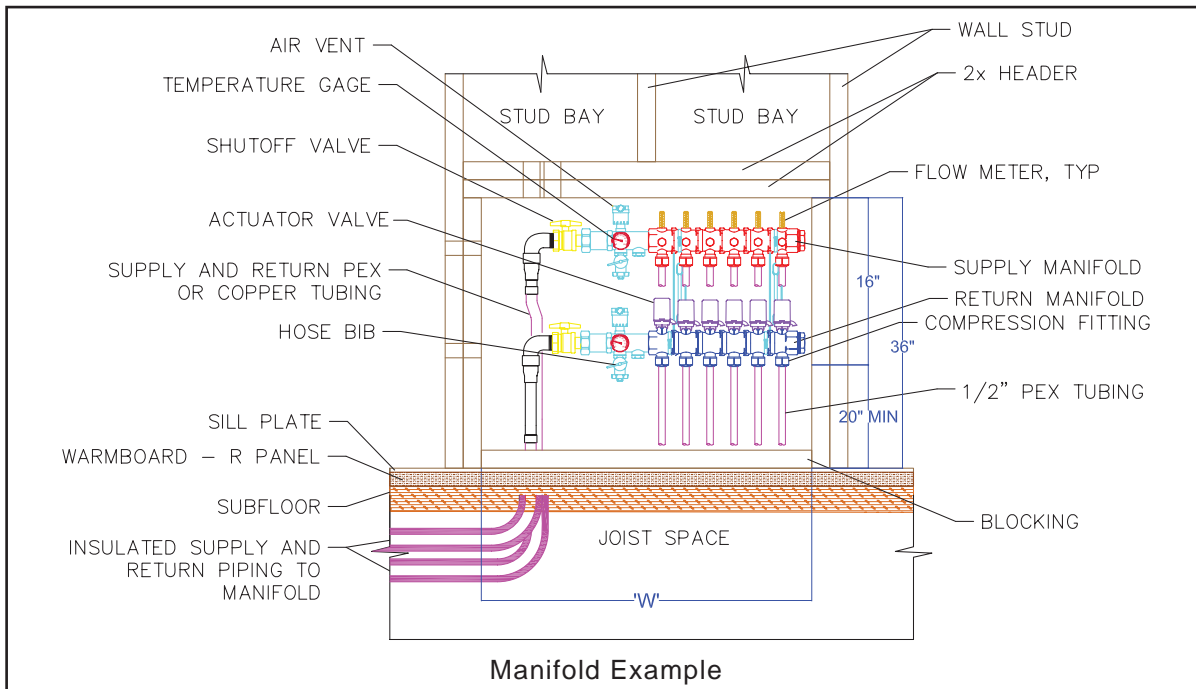

FRAMING DIMENSIONS FOR MANIFOLD BOX

LOOPS	W X H
2	14"X36" CLEAR
3	16"X36" CLEAR
4	18"X36" CLEAR
5	20"X36" CLEAR
6	22"X36" CLEAR
7	24"X36" CLEAR
8	26"X36" CLEAR
9	28"X36" CLEAR
10	30"X36" CLEAR



Installing Solid Wood Flooring Over Warmboard-R

The application of solid hardwood floors installed over a radiant heated floor is approved by many hardwood manufacturers and trade organizations. Warmboard-R installed with hardwood floors is a proven successful technology. If you would like to research this topic, please check out the following:

Radiant Panel Association	www.radiantpanelassociation.org
The Hardwood Council	www.hardwoodcouncil.com
National Wood Flooring Assoc.	www.woodfloors.org
Launstein Floors	www.launstein.com
Lumber Liquidators	www.lumberliquidators.com
Carlisle Wide Plank Floors	www.wideplankflooring.com

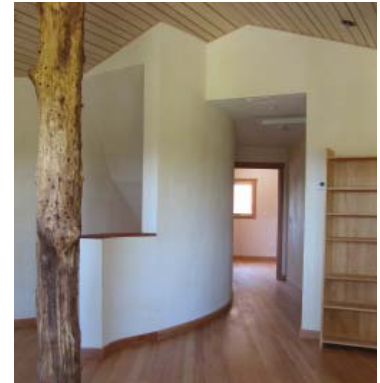

First and Always...

Follow the specifications and recommendations of the wood floor manufacturer.

Also follow all installation specifications and guidelines documented by the National Wood Flooring Association.

- The hygroscopic nature of wood is why wood moves.
- The changing atmosphere of humidity will cause **hardwood** to **expand** and **contract**.
- These changes that finish hardwood floors can experience from humidity swings are referred to as “**gapping**” and “**cupping**.”

Avoiding Gapping and Cupping of Hardwood Floors

Type of Lumber

Use a wood species that is dimensionally stable. There are three types of cuts from the tree: Quartersawn, Riftsawn, and Plainsawn. Quartersawn is nearly all vertical grain lumber which is a better quality cut and dimensionally stable. Riftsawn is the next best choice. Anything wider than 3 1/4” is referred to as plank flooring. Anything narrower than this is called strip flooring. In general, strip flooring is more dimensionally stable. However, plank flooring has been installed over Warmboard-R successfully in many projects with widths of up to 12” on occasion.



Acclimate Wood

Low moisture content of the wood strips is an important condition for stability. It is crucial to acclimate the wood. Bring the wood strips to the job site and sticker them. This means pull them out of their boxes and set them up so air can circulate around them. Acclimation time can vary, but two weeks is recommended. The wood flooring should not be delivered on the job site until the interior plastering is completed and dry.

The radiant floor heating should be in good operation before the hardwood arrives. It is best to operate the radiant floor system for a few weeks to help bring down the moisture content of the Warmboard-R. This procedure should take place no matter what time of year the hardwood is being installed.

Humidity control on the job site is crucial in some areas of the country. It may be required to operate the air conditioner to control the indoor humidity a few days before the wood is delivered. Keeping the indoor humidity between 30%-50% will keep the wood stable.

The hardwood should not experience any large swings in humidity or temperature once it arrives on the job site. It is best to keep the ambient temperature in the house between 60° and 80° and keep the indoor humidity between 30% and 50% range. To meet these specifications, it will be required to operate the radiant floor heating or the air conditioner during wood acclimation and after hardwood installation.

Hardwood floor installers should test the moisture content of the Warmboard-R panel and the wood finish floor prior to an installation. The moisture content of Warmboard-R should be at 12% or less. The moisture content of the finish hardwood should read within 4% of the Warmboard-R reading. The ideal reading of the hardwood would be between 8%-12%, however, this reading can vary in your climate zone.

It is difficult to get a proper moisture content reading from the Warmboard-R panels due to the aluminum skin. For an accurate moisture reading from the top side of the Warmboard-R panel, use a moisture meter with insulated contract pins that have hammer probes. An example of this meter is model J4 or J2000 which is available at www.delmhorst.com.

Be aware of any moisture or humidity intrusion that may take place on a project. For example, a crawl space under Warmboard-R that is dry in the summer and experiences water intrusion in the winter months could cause large humidity swings and movement of the finished hardwood floor (gapping and cupping).



Installing Traditional Strip and Plank Hardwood over Warmboard-R

We recommend three different installation options (all methods are very common)

- 1) Nail the hardwood directly to the Warmboard-R.
- 2) Nail and glue the hardwood directly to the Warmboard-R.
- 3) Glue only, with the use of an interior plywood underlayment (1/4") installed under the hardwood.

First and Always...

Follow the specification and installation recommendations provided by the Hardwood Manufacturer. Also, follow installation specifications and guidelines documented by the National Wood Flooring Association.

Nail the hardwood directly to Warmboard-R

Hardwood should be nailed directly to the Warmboard-R. The required vapor retarder is built into the Warmboard-R panel itself, the aluminum. Do not install any material between the Warmboard-R panel and the hardwood.

Installing the hardwood perpendicular to the tubing pattern is the easiest method. It is important to see the tubing as the planks are nailed to avoid tubing damage. It is recommended to tongue nail at a 45 degree angle at 6" on centers and use 2" flooring nails. Occasionally, the plank flooring will run the same direction as the tubing. When this occurs, either glue with Bostik's Best (bostik.com), SikaBond T35 or T55 urethane adhesive (sikaconstruction.com), or face nail the plank.

Hardwood can be nailed down parallel to the tubing pattern, this method will require extra labor. Strategic planning with the layout can avoid face nailing and gluing in many locations. When gluing is required apply a hardwood urethane adhesive such as applying Bostik's Best (bostik.com), SikaBond T35 or T55 urethane adhesive (sikaconstruction.com).

Nail and glue the hardwood directly to the Warmboard-R

Hardwood should be nailed directly to the Warmboard-R. The required vapor retarder is built into the Warmboard-R panel itself, the aluminum. Do not install any material between the Warmboard-R panel and the hardwood except the glue.

For glue down application trowel on the adhesive directly over the Warmboard-R using Bostik's Best (bostik.com), or SikaBond T35 or T55 urethane adhesive (sikaconstruction.com).

Installing the hardwood perpendicular to the tubing pattern is the easiest method. It is important to see the tubing as the planks are nailed to avoid tubing damage. It is recommended to tongue nail at a 45 degree angle at 6" on centers and use 2" flooring nails. Occasionally, the plank flooring will run the



Installing Traditional Strip and Plank Hardwood over Warmboard-R (con't)

same direction as the tubing. When this occurs, either glue with Bostik's Best (bostik.com), SikaBond T35 or T55 urethane adhesive (sikaconstruction.com), or face nail the plank.

Hardwood can be nailed down parallel to the tubing pattern, this method will require extra labor. Strategic planning with the layout can avoid face nailing and gluing in many locations. When gluing is required apply a hardwood urethane adhesive such as applying Bostik's Best (bostik.com), SikaBond T35 or T55 urethane adhesive (sikaconstruction.com).

Glue Down Method

Warmboard-R has a vapor retarder built into the panel itself, therefore no additional vapor retarder is required.

For glue down applications we do recommend the installation of 1/4" interior A-C rated plywood (or equal) to be installed directly over the Warmboard-R.

This plywood should be fastened securely with screws (construction adhesive is optional). See page 22 of this manual to review the best method to avoid tubing damage by using a quick stencil system.

Follow by troweling Bostik's Best (bostik.com), or SikaBond T35 or T55 urethane adhesive (sikaconstruction.com) over the plywood. Complete with installation of hardwood planks. Follow all installation details documented by the glue manufacturer.

Operating the Radiant Heating System

We recommend circulating low water temperatures for the first few days of operation under newly installed wood floors. Then, gradually bring the water temperature up to the designed set point. For example, start with 90° water and after a few days, bring it up to 100°. Then, finalize a set point of 110°.

It is ideal for the heating system to be designed with a control strategy referred to as Outdoor Reset. This technology sets up a heating curve that will gradually change the delivered water temperature based on the current heat loss of the house. This is an excellent strategy for gradually heating hardwood floors.

Important - Surface temperatures of the installed hardwood should not exceed 85°F.



Installing Engineered, Laminate, and Bamboo Flooring

We recommend four different installation options (all methods are very common)

- 1) Floating floor method
- 2) Glue only, with the use of an interior plywood underlayment (1/4") installed under the planks.
- 3) Nail the planks directly to the Warmboard-R.
- 4) Nail and glue the planks directly to the Warmboard-R.

First and Always...

Follow the specification and installation recommendations provided by the engineered wood or bamboo manufacturer. Also, follow installation specifications and guidelines documented by the National Wood Flooring Association.

Note: Warmboard-R has a vapor retarder built into the panel, therefore no additional vapor retarder is required. Wood can be installed directly over Warmboard-R.

Floating Floor Method

This is a great option because the floorboards are locked together at the joints of each board and not nailed or adhered to the subfloor. This allows the whole floor to move as a single unit if a dimensional change within the floor takes place. There is an acoustic padding available that is placed between the Warmboard-R and the planks. This padding is an excellent upgrade for the system.

Glue Down Method

Warmboard-R has a vapor retarder built into the panel itself, therefore no additional vapor retarder is required.

For glue down applications we do recommend the installation of 1/4" interior plywood with A rated sanded face (or equal) to be installed directly over the Warmboard-R.

This plywood should be fastened securely with screws (construction adhesive is optional). See page 22 of this manual to review the best method to avoid tubing damage by using a quick stencil system.

Follow by troweling Bostik's Best (bostik.com), or SikaBond T35 or T55 urethane adhesive (sikaconstruction.com) over the plywood. Complete with installation of planks. Follow all installation details documented by the glue manufacturer.

Nail Down Method

Planks should be nailed directly to the Warmboard-R. The required vapor retarder is built into the Warmboard panel itself, the aluminum. Do not install any material between the Warmboard-R panel and the planks.



Installing Engineered, Laminate and Bamboo Flooring (con't)

Installing the planks perpendicular to the tubing pattern is the easiest method. It is important to see the tubing as the planks are nailed to avoid tubing damage. It is recommended to tongue nail at a 45 degree angle at 6" on centers and use 2" flooring nails. Occasionally, the plank flooring will run the same direction as the tubing. When this occurs, either glue with Bostik's Best (bostik.com), SikaBond T35 or T55 urethane adhesive (sikaconstruction.com), or face nail the plank.

Planks can be nailed down parallel to the tubing pattern, this method will require extra labor. Strategic planning with the layout can avoid face nailing and gluing in many locations. When gluing is required apply a engineered wood urethane adhesive such as applying Bostik's Best (bostik.com), SikaBond T35 or T55 urethane adhesive (sikaconstruction.com)

Nail and glue the engineered wood directly to the Warmboard-R

Planks should be nailed directly to the Warmboard-R. The required vapor retarder is built into the Warmboard-R panel itself, the aluminum. Do not install any material between the Warmboard-R panel and the planks except the glue.

For glue down application trowel on the adhesive directly over the Warmboard-R using Bostik's Best (bostik.com), or SikaBond T35 or T55 urethane adhesive (sikaconstruction.com).

Installing the planks perpendicular to the tubing pattern is the easiest method. It is important to see the tubing as the planks are nailed to avoid tubing damage. It is recommended to tongue nail at a 45 degree angle at 6" on centers and use 2" flooring nails. Occasionally, the plank flooring will run the same direction as the tubing. When this occurs, either glue with Bostik's Best (bostik.com), SikaBond T35 or T55 urethane adhesive (sikaconstruction.com), or face nail the plank.

Planks can be nailed down parallel to the tubing pattern, this method will require extra labor. Strategic planning with the layout can avoid face nailing and gluing in many locations. When gluing is required apply a engineered wood urethane adhesive such as applying Bostik's Best (bostik.com), SikaBond T35 or T55 urethane adhesive (sikaconstruction.com).

Acclimate Wood

Review page 14 of this manual for important information.

Important - Surface temperatures of the installed hardwood should not exceed 85°F.



Hardwood Manufacturers

Company	Phone	Website	Engineered Products Approved for Radiant	Solid Wood Products Approved for Radiant
Anderson Wood Floors	864-833-6250	www.andersonfloors.com	some	no
Armstrong, Bruce, Robbins	800-233-2823	www.armstrong.com	some	no
Arrigoni Woods	888-423-6668	www.arrigoniwood.com	yes	yes
Authentic Pine Floors	800-283-6038	www.authenticpinefloors.com	yes	yes, 6" wide and less
Award Hardwood Floors	715-849-8080	www.awardfloors.com	yes	yes
Bellawood Hardwood Floors	800-HARDWOOD	www.bellawood.com	yes	yes
Boen Hardwood Floors	888-897-0800	www.boen.com	yes	N/A
BR-111 Exotic Hardwood Floors	800-525-2711	www.br111.com	yes	no
Broad-Axe Beam Company	802-257-0064	www.broad-axebeam.com	N/A	yes
Carlisle Wide Plank	800-595-9663	www.wideplankflooring.com	N/A	yes
Columbia Forest Products	800-654-8796	www.columbiaflooring.com	yes	no
Goodwin Heart Pine Company	800-336-3118	www.heartpine.com	N/A	yes
Hallmark Hardwood Floors	888-551-0888	www.hallmarkhardwoods.com	yes	yes
Heartwood Pine Flooring	800-524-7463	www.heartwoodpine.com	yes	yes
Heritage Wide Plank Flooring	877-777-4200	www.heritagewideplankflooring.com	N/A	yes
Homerwood Hardwood Flooring	814-827-3855	www.homerwood.com	yes	yes
Junckers Hardwood Flooring	800-878-9663	www.junckersh hardwood.com	most	yes
Karelia Hardwood Floors	888-840-3435	www.kareliafloors.com	N/A	most
Launstein Floors	888-339-4639	www.launstein.com	yes	yes
Lauzon Hardwood Flooring	877-427-5144	www.lauzonltd.com/index_en.html	yes	no
LM Flooring	972-417-9900	www.lmflooring.com	some, floating only	N/A
Mannington Wood Floors	856-935-3000	www.mannington.com	yes	yes
Max Windsor Hardwood Floors	909-477-6698	www.maxwindsor.com	most	N/A
Mercier Wood Floors	800-463-7048	www.mercierwoodflooring.com	most	most
Mirage Floors	800-463-1303	www.miragefloors.com	yes	most
Mountain Lumber	800-445-2671	www.mountainlumber.com	yes	yes
Muskoka Hardwood Flooring	800-461-5386	www.muskokaflooring.com	yes	no
Mohawk Hardwood Flooring	800-266-4295	www.mohawk-flooring.com	yes	no
Nordstar Hardwood Flooring	207-799-0010	www.nordstar.net	some	N/A
Satin Finish Hardwood Flooring	800-60-SATIN	www.satinfinish.com	yes	no
Shaw Hardwood Floors	800-441-7429	www.shawfloors.com	some	no
Southern Wood Floors	888-488-7463	www.southernwoodfloors.com	yes	no
Swedish Flooring	360-752-0350	www.swedishflooring.com	yes	N/A
Tarkett Wood Floors	800-842-7816	www.tarkett-floors.com	some	no
The Woods Company	888-548-7609	www.thewoodscompany.com	N/A	yes
Torlys	800-461-2573	www.torlys.com	yes	N/A
What It's Worth	512-328-8837	www.wiwpine.com	N/A	yes
Zickgraf Hardwood Company	800-243-1277	www.zickgraf.com	N/A	yes, less than 5"

For technical assistance call Warmboard toll-free 1-877-338-5493



Installing Tile Over Warmboard-R

Important - The TCA specifies that tile should never be installed directly over a remodel panel without the use of one of the methods listed below; either a mortar bed or a backer board installed between the remodel panel and the tile.

Installation methods recommended by the TCA:

Method 1 - Mortar Beds

Mortar beds have been the traditional method of addressing the expansion, contraction and deflection properties of wooden subfloors. They have the advantage that by their very nature they provide a thick, continuous, stable surface to which tile readily adheres. They have the disadvantage that they tend to be expensive, add significant mass to a system, and due to their thickness, often cause the elevation of tile areas to not match up well with adjacent carpeted or hardwood areas. When applying mortar beds, either a 15-lb. felt, or a 4-mil polyethylene membrane preparation can be used. Fasten down a metal lath over the membrane and finish with a minimum 3/4" mortar bed. After the mortar bed has cured, thin set and tile may then be applied.

Note: Care should be taken to avoid tubing damage.

Method 2 - Backer Boards

There are a variety of cementitious backer boards available that range in thickness from 1/4" to 1/2". Because all substrates fail to be perfectly flat, these backer boards will provide a more stable surface when they are installed over the Warmboard-R panels. Prior to installation, apply thin set to the bottom side of the backer board using a 1/4" square-notched trowel.

Immediately fasten the backer board before the thin set dries, following recommendations of the backer board manufacturer (typically, fasten using special screws). Please note that backer board panels should run perpendicular to Warmboard-R panels and seams should be staggered so as not to line up with the Warmboard-R panel seams. Care should be taken during fastening to note tubing positions and avoid them. Backer boards have the advantage that they have low mass, are quick and relatively inexpensive to install, and that because of the thicknesses available, provide a base for tiled areas to match up well with adjacent floor coverings. See page 22 for more installation tips.

Method 3 - Schluter - DITRA

Ditra is a polyethylene membrane with a grid structure of square cut cavities and an anchoring fleece laminated to its underside. Apply a layer of Mapei –“Granirapid”, a Premium Rapid-Setting, Flexible-Polymer Modified Mortar directly to the Warmboard-R panels, using a 1/4" or 5/16" V-notch trowel, and then install the Ditra grid. (An equivalent brand of a Rapid-Setting, Polymer Modified Mortar that meets and exceeds ANSI A118.4 can be used) Wait until the mortar is completely dry below the Ditra. Then trowel on an unmodified thin set mortar that meets and exceeds ANSI A118.1 on the topside of the Ditra, and immediately install tile or stone. There have been hundreds of successful tile installations installed by this method with no reports of problems or failure.



Installing Tile Over Warmboard (con't)

However, Schluter does not warranty this installation pending further testing. The tile floor covering warranty may be invalidated by the assembly mentioned. Another option is the installation of a backer board or a 1/4" or 1/2" APA listed plywood underlayment between the Ditra and the Warmboard-R panels. For complete installation details, refer to the "Engineered Wood Construction Guide" at www.apawood.org.

Important - Do not let surface temperatures of tile exceed 85°

Please note: Warmboard, Inc. is not an agent for the manufacturers listed below, and gives no actual or implied warranty of fitness for any of these products or manufacturers.

A word of caution: Whatever method you use, make sure that the product meets the standards set forth and accepted by the TCA, ANSI, and the ICC (formerly ICBO). Be sure to follow each manufacturer's specific recommendations when using these products.

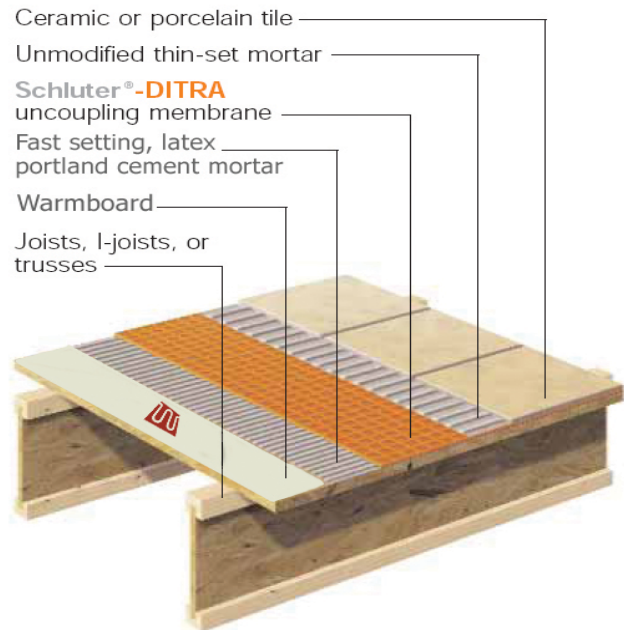

Resources:

American National Standards Institute (ANSI)	http://www.ansi.org
Tile Council of America (TCA)	http://www.tileusa.com
National Tile Contractors Association (NTCA)	http://www.tile-assn.com

Ceramic Tile Backer Board Resources:

Durock	http://www.usg.com/brands/drck.asp
Fiberock	http://www.usg.com/brands/fbrck.asp
Hardibacker	http://www.jameshardie.com/backerboard/default.php
Mapei	http://www.mapei.us/
Wonderboard	http://www.custombuildingproducts.com/onlyproducts/WonderBoard12.htm



Installing Backerboard Over Warmboard-R

Overview

With the use of a clear thin polyethylene plastic sheeting (3 or 4 mil) and a permanent marker, you can quickly create a stencil of the actual tubing pattern. By placing this custom stencil over the backerboard you can safely install all of your fasteners and avoid tubing damage.



1) Cut polyethylene plastic to size of backerboard. To save time cut all of your full size 3'x5' plastic stencils at once. **Caution:** do not cut directly on the Warmboard-R / tubing.



2) Place the precut plastic over the Warmboard-R and tape the corners down. With a permanent marker trace the tubing pattern onto the plastic. Also clearly mark top and bottom on stencil, then carefully remove plastic and lay flat next to work area.



3) Place a butter coat of thin set on back side of backerboard (see page 18 for details) and place over the appropriate Warmboard-R location.



4) Slide plastic stencil in appropriate location over the backerboard and tape corners down. Complete process by marking with a drill bit all safe fastening locations, then remove plastic stencil and fasten as normal.



Installing Carpet Over Warmboard-R

Padding and carpet is a very common finish floor to use over Warmboard-R. The carpet cushion (padding) can be installed directly over the Warmboard-R panels. Before installing the carpet cushion it is necessary to fill all of the empty grooves to provide an even surface for installation. Empty grooves can be filled with scrap pex tubing. Another option is to use a floor leveling compound or Portland cement to fill the empty grooves making them flush and level with the panel surface. Do not install padding and carpet until all the loops have been properly pressure tested.

When choosing a carpet cushion/carpet assembly we recommend a product that has a low R-value rating. The advantage of using a product with a low R-value is to keep the radiant floor system very simple. Meaning the system can use the same water temperatures for the tile, hardwood, and carpet in a home. This type of system is referred to as a one temperature system. To achieve a simple one temperature system, it is best to purchase a carpet and carpet cushion assembly that does not exceed an R-value of 2. If the R-value assembly exceeds R-2, a two temperature system may be required.

The Radiant Panel Association recommends that the surface temperature of carpet does not exceed 85 degrees. Warmboard, Inc. supports this RPA recommendation.

For other carpet cushion options review Group Two on page 24.

Sponge Cushion

Tel:1-800-435-4062

Fax: 800-423-3557

<http://www.sponge-cushion.com>

Product	R-Values
Luxury Step	.80
Full House	.68
Berber Supreme	.59
Berber Master	.35
Silent Walk	.46
SP 380	.66
Tred-MOR 1562	.27
Tred-MOR 2568	.46
Tred-MOR 2580	.48
Tred-MOR 2500	.34
Deci-BLOK	.10

Leggett & Platt

Tel: 1-800-866-9446

<http://www.lpurethane.com/rubber.asp>

Product	R-Values
STAINMASTER® Ultra (APC)	.80
STAINMASTER® Plus (APC)	.70
Deluxe	.68
Martinique	.73
Rise	.80
Brava	.69
Plushmate	.74
Superba	.70
GrandStand	.68
Barcelona	.44
Thunder Bay	.50
Pure Comfort	.68



Carpet and Padding R-Values

Carpet Thickness	R-Value
1/8"	R-0.6
1/4"	R-1.0
1/2"	R-1.4
3/4"	R-1.8
1"	R-2.2

Carpet Cushion R-Value					
<i>In General</i>					
Group One					
	Density	Thickness	R-Value		
Prime Urethane	2.2 lb/cu ft	1/4"	R-1.08	Not Recommended	
		3/8"	R-1.62		
		1/2"	R-2.15		
Bonded Urethane	4-8 lb/cu ft	5/32"	R-0.66	Not Recommended	
		1/4"	R-1.05		
		3/8"	R-1.57		
		7/16"	R-1.84		
		1/2"	R-2.09		
Sunburst Family	10 lb/cu ft			Not Recommended	
		SunBerber	3/8"		R-1.16
		Sunburst	15/32"		R-1.43
		BerberGuard	3/8"		R-1.25
		SunGuard	15/32"		R-1.50
Group Two					
	Density	Thickness	R-Value		
Fiber/Hair/Jute	6-8 lb/cu ft	1/4"	R-0.97	3rd Choice	
		3/8"	R-1.46		
		1/2"	R-1.94		
Waffle Rubber	25 lb/cu ft	1/4"	R-0.62	2nd Choice	
		3/8"	R-1.00		
		1/2"	R-1.33		
Slab Foam Rubber	33 lb/cu ft	1/4"	R-0.31	Best Choice	
		3/8"	R-0.47		
		1/2"	R-0.62		
NOTE: All R-Values are approximate. Check with product manufacturer for actual R-Values					



Installing Cork Flooring Over Warmboard-R

Always follow the specifications and installation specifications provided by the cork manufacturer.

The surface temperature of the installed cork should not exceed 85 degrees.

Cork flooring has a naturally high insulation value so it is important to choose one that is 3/8 to 1/2 inch in thickness when working with radiant heat. This will keep the R value to 1.5 or less giving better heating and response times, while simplifying the mechanical design at the same time. A more simple mechanical design means your cork floor will operate in the same water temperature range as tile, hardwood or carpet. Please always note that all finish floors including cork should never exceed 85 degree surface temperature.

Some well known industry brands are Expanko Cork (www.expanko.com), American Cork (www.amcork.com), and Natural Cork (www.naturalcork.com).

Installation Method #1: Standard Cork Flooring

The installation of an underlayment is required over the Warmboard-R surface before standard cork flooring is installed. Care should be taken when fastening the underlayment to Warmboard-R because the tubing is obscured during this step. See page 22 of this manual to review the best method to avoid tubing damage by using a quick stencil system. Warmboard-R recommends installing a 1/4" APA listed plywood underlayment with a sanded face. For complete installation details, refer to the "Engineered Wood Construction Guide" at www.apawood.org. **Complete the installation of the cork by following all the manufacturer guidelines and specifications.**

Once the underlayment is installed, the cork is adhered using a urethane adhesive made for cork applications. A good product to use is Dri Tac 7500 (www.dritac.com - 1-800-726-7845).

Installation Method #2: Cork Laminate Products

Cork laminate products work well with Warmboard-R as well. These products are manufactured with cork on the top and bottom and an MDF layer sandwiched in between. It is not necessary to put any barrier between the cork flooring and Warmboard-R prior to installation. The advantage of this type of cork floor is that it installs as a floating floor and requires no adhesive or nailing for proper installation. This allows the homeowner more flexibility if they ever decide to change the floor covering.



Installing Vinyl Over Warmboard-R

There are many different types of vinyl flooring available and each can be used with the Warmboard-R system. The inlaid vinyl type or vinyl inner layer is the most durable. Vinyl floors are manufactured with a sandwich of layers. It starts with a felt or vinyl backing, then the vinyl granules are put directly on the backing all the way up to the wear surface.

First and Always...

Follow the specifications and installations specifications provided by the vinyl manufacturer.

The installation of underlayment is required over the Warmboard-R before the vinyl is installed. Care should be taken when fastening the underlayment to Warmboard-R because the tubing is obscured during this step. See page 22 of this manual to review the best method to avoid tubing damage by using a quick stencil system. Warmboard, Inc. recommends installing a 1/4" or 1/2" APA listed plywood underlayment with a sanded face. For complete installation details, refer to the "Engineered Wood Construction Guide" at www.apawood.org. **Complete the installation of vinyl by following all the manufacturers guidelines and specifications.**

Important - The surface temperature of the installed vinyl should not exceed 85°.



Installing Linoleum Over Warmboard-R

Linoleum is a floor covering made from solidified linseed oil in combination with flour or cork dust over a burlap or canvas backing. As an all natural product, linoleum offers many advantages and interfaces well with Warmboard-R.

First and Always...

Follow the specifications and installation recommendations provided by the linoleum manufacturer.

The installation of underlayment is required over the Warmboard-R before the linoleum is installed. Care should be taken when fastening the underlayment to Warmboard-R because the tubing is obscured during this step. See page 22 of this manual to review the best method to avoid tubing damage by using a quick stencil system. Warmboard, Inc. recommends installing a 1/4" or 1/2" APA listed plywood underlayment with a sanded face. For complete installation details refer to "Engineered Wood Construction Guide" at www.apawood.org. **Complete with installation of linoleum, follow all the manufactures guidelines and specifications.**

Important - The surface temperature of the installed linoleum should not exceed 85°.



Installing Warmboard-R Over an Existing Concrete Slab

In situations where the existing concrete is not level and flat, the 4'x8', 1-1/8" Warmboard tongue and groove panel will be more suitable for these applications.

Concrete Slab Requirements

The existing slab must be level. A newly poured slab needs to be well cured which requires a minimum of 28 days. A moisture test should be conducted prior to installation to ensure the slab is properly cured. The slab must have sufficient drainage from rain and snow on a year round basis. If Warmboard R-panels are exposed to any water intrusion or any moisture problems, the wood will rot. Do not use Warmboard R-panels if these environmental conditions are possible.

When Warmboard-R Panels are being installed over an existing slab, it is crucial for the panels never to be exposed to weather. If the Warmboard R-Panels are exposed to rain or snow, the moisture will be trapped in the panel and wood rot will take place.

Testing For Moisture

There are several possible methods by which to test the moisture content of a newly poured slab, the simplest being "The Plastic Sheet Method" (ASTM D 4263-83). For this method, seal an 18-inch x 18-inch square of clear plastic sheet to the slab with tape on all 4 sides. If, after 16 hours, any condensation is found on the underside of the plastic or if the surface of the concrete is darkened, the concrete is considered too wet for a covering application. Do not allow the sheet to come in contact with direct sunlight or excessive heat.

It is possible for this particular method to yield a false result, giving the impression that the slab is fully cured, when in fact it still contains moisture. For example, in cooler conditions, the concrete may retain its moisture and fail to condense on the plastic. However, an obvious appearance of moisture in this method almost always indicates excessive moisture.

With the Plastic Sheet Method, the best way to ensure a reliable result is to make sure that the surface temperatures and ambient conditions during the test are very similar to those present after the Warmboard-R is installed.

If no moisture test is conducted, we recommend giving a newly poured slab 90 days to cure fully.

Installation Method

Install a vapor retarder directly to the slab. We recommend either a 6-mil or a 10-mil polyethylene overlapped two feet (2') at the seams. Continue with Warmboard-R Panel installation with the use of Tap Con concrete fasteners. We recommend a minimum of 9 fasteners for each panel.

An excellent resource for a combination vapor retarder and rigid foam insulation can be found at: www.thebarrierinsulation.com.

Installation Tip

Before installation of a Tap Con fastener, drill a pilot hole 1.5" deeper than the Tap Con will reach. Draw the bit in and out of the pilot hole repeatedly to loosen excess material. Then remove the excess using a shop vacuum.



Installing Warmboard-R Over an Existing Concrete Slab (con't)

Fastening Pattern for Warmboard-R

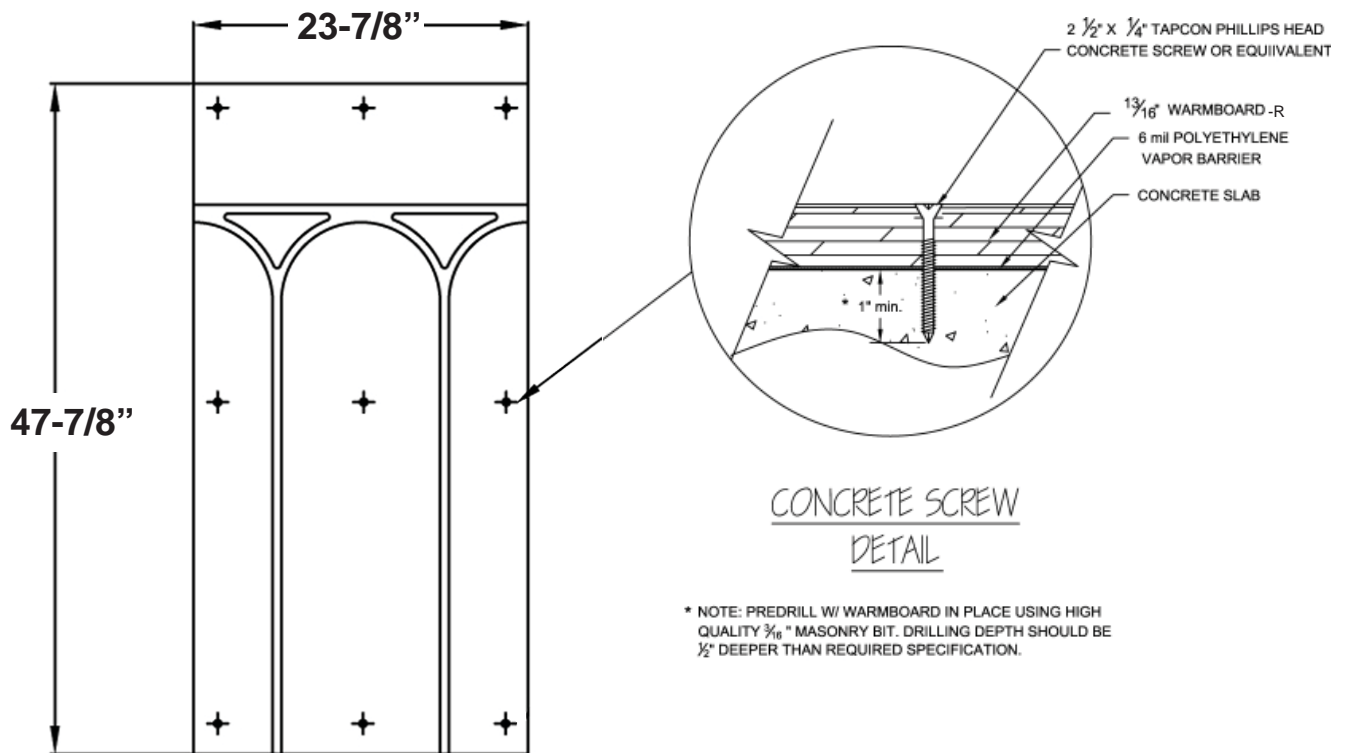



Tubing Repair

During installation, if the tubing is damaged or punctured, a repair coupling must be installed. It is crucial for the tubing manufacturer to provide the repair components. For example, if the brand of tubing installed is Watts, the repair assembly to be purchased must be manufactured by Watts. Generally, a nipple and two compression fittings would be used. These fittings are too large for our Warmboard-R channel so the channel where the repair will be placed must be modified. The depth and width of the groove should be enlarged with the use of hand tools or power tools. We recommend a sharp hand chisel, grinder, or a router.





Water Temperature Chart at 70° Indoor Ambient Temp.

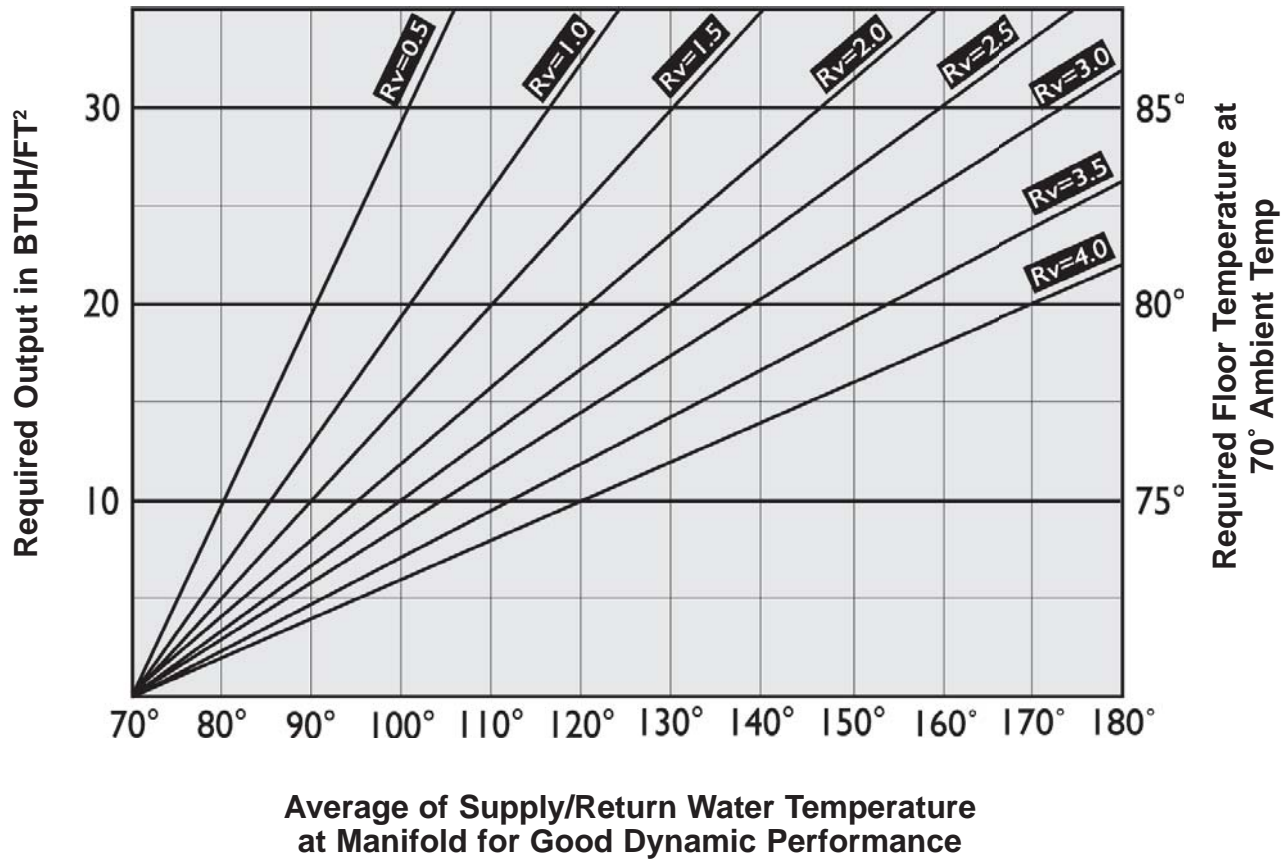

NOTES:

1. Steady State Performance will require 10% lower supply temperature.
2. Rv = Floor Covering Resistance Value.
3. Warmboard, Inc. recommends maximum floor temperature of 85°.
4. Assumes minimum R21 insulation below floor.
5. Warmboard-R is one component of a complete system.
6. Complete system design shall be performed in accordance with Radiant Panel Association (RPA) Guidelines, manufacturers' recommendations for ancillary components, and is the responsibility of the system designer.
7. Assumes a Designed Ambient Air Temp of 70° Fahrenheit.



Finish Floor R-Values

Material	Typical R-value	R-value per Inch	Typical Thickness
Plywood	0.825	1.10	0.750
OSB	1.050	1.40	0.750
Softwood	0.825	1.10	0.750
Ash	0.750	1.00	0.750
Maple	0.750	1.00	0.750
Oak	0.638	0.85	0.750
Pine	0.975	1.30	0.750
Fir	0.900	1.20	0.750
Engineered Bamboo	0.720	0.96	0.750
Engineered Wood	0.250	1.00	0.250
Engineered Wood	0.375	1.00	0.375
Engineered Wood	0.625	1.00	0.625
Engineered Wood	0.750	1.00	0.750
Engineered Wood Flooring Pad	0.200	1.60	0.125
Carpet Pad/Slab Rubber 33 lb	0.320	1.28	0.250
Carpet Pad/Slab Rubber 33 lb	0.480	1.28	0.375
Carpet Pad/Slab Rubber 33 lb	0.640	1.28	0.500
Carpet Pad/Waffle Rubber 25 lb	0.620	2.48	0.250
Carpet Pad/Waffle Rubber 25 lb	1.240	2.48	0.500
Hair Jute	1.940	3.88	0.500
Hair Jute	1.250	3.88	0.325
Prime Urethane	1.400	4.30	0.325
Prime Urethane	2.150	4.30	0.500
Bonded Urethane	1.350	4.20	0.325
Bonded Urethane	2.100	4.20	0.500
Carpet	0.700	2.80	0.250
Carpet	1.050	2.80	0.375
Carpet	1.400	2.80	0.500
Carpet	1.750	2.80	0.625
Carpet	2.100	2.80	0.750
Wool Carpet	1.575	4.20	0.375
Wool Carpet	2.100	4.20	0.500
Sheet Vinyl	0.200	1.60	0.125
Vinyl Composition Tile (VCT)	0.200	1.60	0.125
Linoleum	0.400	1.60	0.250
Linoleum	0.200	1.60	0.125
Dense Rubber Flooring	0.250	1.30	0.325
Recycled Rubber Flooring	1.100	2.20	0.500
Cork	1.125	3.00	0.375
Cork/MDF/Laminate	1.175	2.35	0.500
Brick	3.375	2.25	1.500
Marble	0.400	0.80	0.500
Ceramic Tile	0.250	1.00	0.250
Thinset Mortar	0.050	0.40	0.125
MDF/Plastic Laminate	0.500	1.00	0.500
Laminate Floor Pad	0.300	1.92	0.160